

⚠ WARNING

- Obtain, read and carefully service instructions when installing parts. A loose, worn, or damaged parts may cause injury to the rider.
- We strongly recommend that only genuine Shimano replacement parts be used.

SERVICE INSTRUCTIONS SI-1DPOA

FC-3300 FC-3303

Front chainwheel

Before use, read these instructions carefully, and follow them for correct use.

Product specifications

Front Chainwheel

Model number	FC-3300	FC-3303
Chainwheel teeth	50/39T	52 / 42 / 30T
Bolt circle diameter	130 mm	130 / 74 mm
Crank arm length	165, 170, 175 mm	165, 170, 175 mm
Pedal threads	BC 9/16"x20 T.P.I.	BC 9/16"x20T.P.I.
Applicable chain	CN-HG50	CN-HG50
Applicable bottom bracket	BB-UN25	BB-UN25

Bottom Bracket

Model number	BB-UN25	BB-UN25
Type	double	Triple
Spindle length	110 mm	113 mm
Chain line	43.5 mm	45 mm
Thread dimensions	68 mm (1.37 X 24 T.P.I.) 70 mm (M36 X 24 T.P.I.)	68 mm (1.37 X 24 T.P.I.) 70 mm (M36 X 24 T.P.I.)

Note

- Apply grease to the bottom bracket before installing it.
- To ensure the best performance, be sure to use only the specified type of chain. The wide type of chain cannot be used.
- For any questions regarding methods of installation, adjustment, maintenance or operation, please contact a professional bicycle dealer.

Installation of the bottom bracket

Install using the special tool TL-UN74. First install the main body, then the adapter.

Tightening torque:
50 - 70 Nm
{435 - 608 in. lbs.}

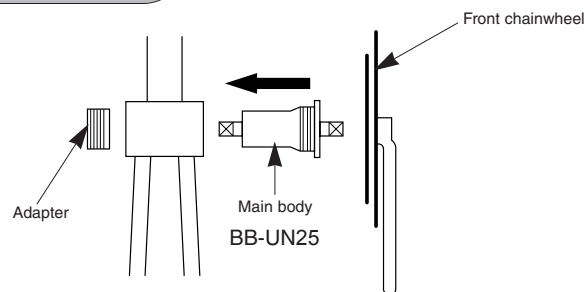

Installation of the chain rings

Smooth shifting will not be possible if the chain rings are incorrectly installed, so be sure to install them in the correct positions.

For both the large and small chainrings, the surfaces that have the tooth number marking should face outward. Install so that the markings are in the positions shown in the illustration.

FC-3303

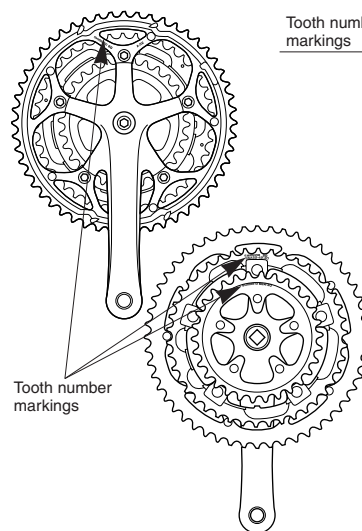

FC-3300

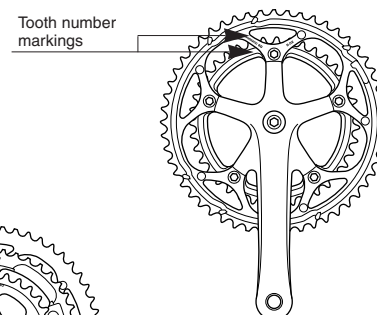

For the FC-3303, the tooth number marking on the largest chainring should face outward, and the markings on the intermediate and smallest chainrings should face inward.

Installation of the front chainwheel

Tightening torque:
35 - 50 Nm
{305 - 435 in. lbs.}

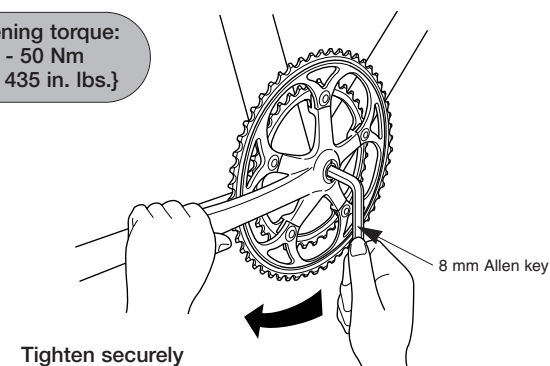

Installation to the fram

- Install and then adjust the front derailleur as shown in the illustration.

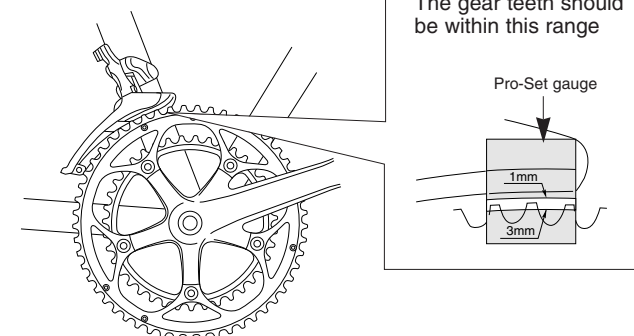

- The level section of the chain guide outer plate should be directly above and parallel to the largest chainring.
- Adjust the derailleur using a 5 mm Allen key.

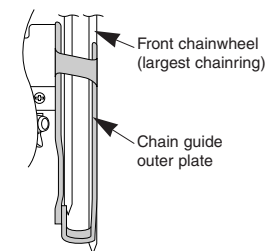

Tightening torque:
5 - 7 Nm
{44 - 60 in. lbs.}

SHIMANO®

SHIMANO AMERICAN CORPORATION
One Holland Irvine CA 92618 U.S.A. Phone 949-951-5003

SHIMANO EUROPA
Industrieweg 24 NL-8071 CT Nunspeet Holland Phone 31-341-272222

SHIMANO INC.
77 Oimatsu-cho 3-cho Sakai Osaka 590-8577 Japan Phone 0722-23-3243
(English)

Please note: specifications are subject to change for improvement without notice.
© Apr. 1999 by Shimano Inc. XBC SZK Printed in Japan.

These service instructions are printed on recycled paper and can be recycled again

