

## WARNING

- Obtain, read and carefully service instructions when installing parts. A loose, worn, or damaged parts may cause injury to the rider. We strongly recommend that only genuine Shimano replacement parts be used.

## SERVICE INSTRUCTIONS SI-5EY0A

# FD-3303

Front derailleur

Before use, read these instructions carefully, and follow them for correct use.

In order to realize the best performance, we recommend that the following combination be used.

|                            |                |
|----------------------------|----------------|
| Series                     | SORA           |
| Shifting lever             | ST-3303        |
| Outer casing               | SP40           |
| Gears                      | 24             |
| Front derailleur           | FD-3303/4      |
| Front chainwheel           | FC-3303        |
| Bottom bracket             | BB-UN40(113mm) |
| Rear derailleur            | RD-3300-GS     |
| Freehub                    | FH-3300        |
| Cassette sprocket          | CS-HG50-8      |
| Chain                      | CN-HG70        |
| Bottom bracket cable guide | SM-SP17        |

## Specifications

| Type   | Band type / Brazed on type |
|--|----------------------------|
| Front chainwheel tooth difference            | 22 teeth or less           |
| Min. difference between top and intermediate | 10T                        |
| Front derailleur installation band diameter  | S (28.6mm), M (31.8mm)     |
| Chainstay angle ( $\alpha$ )                 | 63° - 66°                  |
| Chain line                                   | 45mm                       |

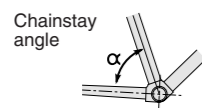

## Note

- If attaching the FD-3303 (brazed-on type) to a seat tube with a thickness of more than 31.8 mm, the derailleur may come into contact with the seat tube and interfere with normal gear shifting performance.
- For smooth operation, always be sure to use the specified outer casing and the bottom bracket cable guide.
- Grease the inner cable and the inside of the outer casing before use to ensure that they slide properly.
- This front derailleur is for triple front chainwheel use only. It cannot be used with the double front chainwheel, as the shifting points do not match.
- For the chain, be sure to use only the Shimano narrow type chain. The wide type chain cannot be used.
- For any questions regarding methods of installation, adjustment, maintenance or operation, please contact a professional bicycle dealer.

## Installation of the front derailleur

Adjust and then install the front derailleur as shown in the illustration. Do not remove the Pro-Set alignment block at this time.

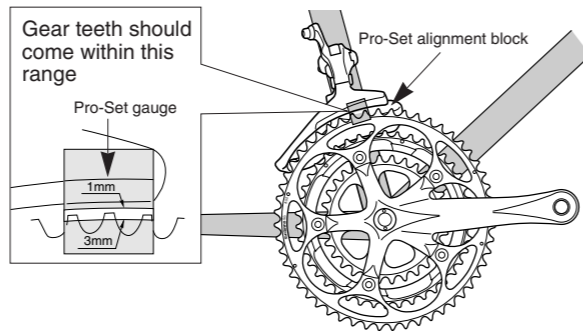

The level section of the chain guide outer plate should be directly above and parallel to the largest chainring. Secure using a 5mm Allen key.

Tightening torque:  
5 - 7 Nm  
{44 - 60 in. lbs.}

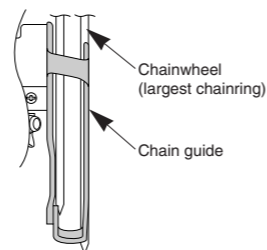

## SIS adjustment

Be sure to follow the sequence described below.

### 1. Low adjustment

First remove the Pro-Set alignment block. Next, set so that the clearance between the chain guide inner plate and the chain is 0-0.5mm.

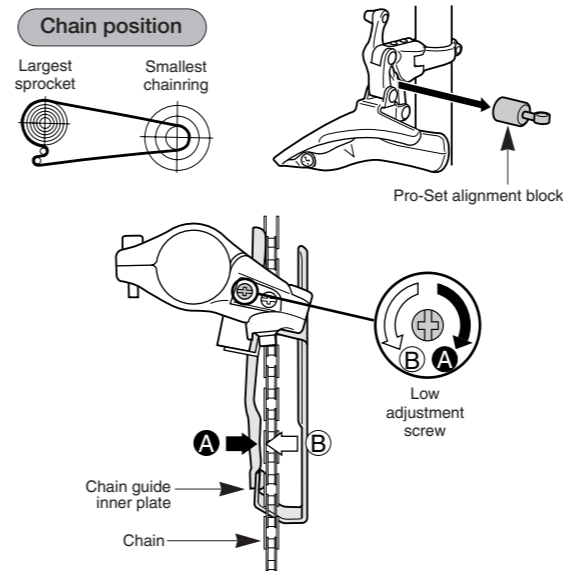

### 2. Connection and securing of cable

While pulling the inner cable, tighten the wirw fixing bolt with a 5 mm allen key to secure the cable.

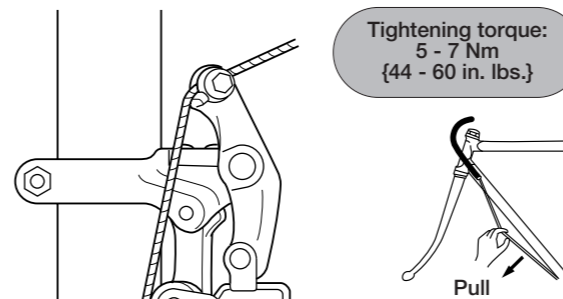

After taking up the initial slack in the cable, re-secure to the front derailleur as shown in the illustration.

### 3. Top adjustment

Set so that the clearance between the chain guide outer plate and the chain is 0-0.5 mm.

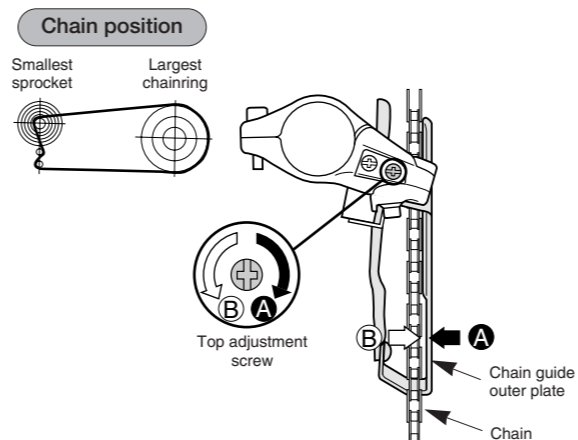

### 4. Adjustment of the intermediate chainring

When carrying out adjustment, set the chain to the largest sprocket, and at the front, set the chain to the intermediate chainring. Adjust using the outer casing adjustment barrel so that the clearance between the chain guide inner plate and the chain is 0-0.5 mm.

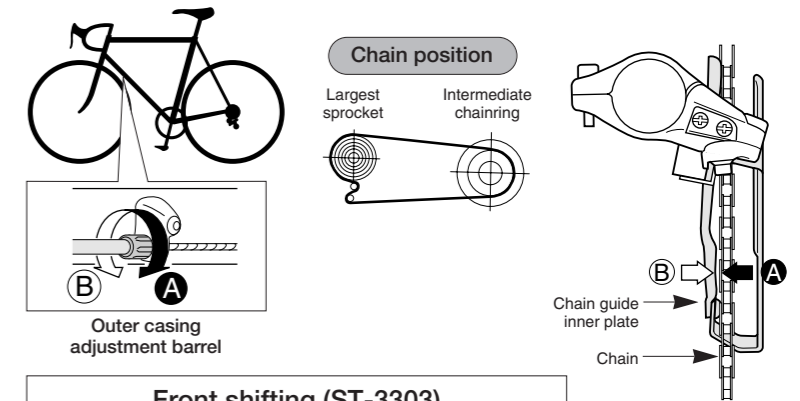

### Front shifting (ST-3303)

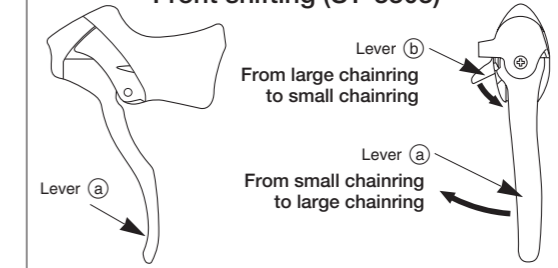

### 5. Troubleshooting chart

After completion of steps 1 - 4, move the shifting lever to check the shifting. (This also applies if shifting becomes difficult during use.)

|  |  |
|--|--|
| If the chain falls to the crank side   | Tighten the top adjustment screw clockwise (about 1/4 turn).               |
| If shifting is difficult from the intermediate chainring to the largest chainring  | Loosen the top adjustment screw counterclockwise (about 1/8 turn).         |
| If shifting is difficult from the intermediate chainring to the smallest chainring   | Loosen the low adjustment screw counterclockwise (about 1/4 turn).         |
| If there is interference between the chain and the front derailleur inner plate at the largest chainring   | Tighten the top adjustment screw clockwise (about 1/8 turn).               |
| If there is interference between the chain and the front derailleur outer plate at the largest chainring   | Loosen the top adjustment screw counterclockwise (about 1/8 turn).         |
| If the intermediate chainring is skipped when shifting from the largest chainring  | Loosen the outer casing adjustment barrel counterclockwise (1 or 2 turns). |
| If there is interference between the chain and front derailleur inner plate when the rear sprocket is shifted to the largest sprocket when the chainwheel is at the intermediate chainring position. | Tighten the outer casing adjustment barrel clockwise (1 or 2 turns).       |
| If the chain falls to the bottom bracket side.   | Tighten the low adjustment screw clockwise (about 1/2 turn).               |

Be sure to read these service instructions in conjunction with the service instructions for the ST-3303 before use.

# SHIMANO®

SHIMANO AMERICAN CORPORATION  
One Holland Irvine CA 92618 U.S.A. Phone 949-951-5003

SHIMANO EUROPA  
Industrieweg 24 NL-8071 CT Nunspeet Holland Phone 31-341-272222 77 Oimatsu-cho 3-cho Sakai Osaka 590-8577 Japan Phone 0722-23-3243

Please note: specifications are subject to change for improvement without notice. (English)  
© Apr. 1999 by Shimano Inc. XBC SZK Printed in Japan.

These service instructions are printed on recycled paper and can be recycled again.

